

Circuit Building Instructions Sheet

The components:

- 1 Arduino Uno Development Board or equivalent
- 1 breadboard
- 1 USB cable, for powering Arduino/uploading code
- 10 wires to connect components
- 3 LEDs
- 1 TMP36 temperature sensor
- 3 220 ohm (Ω) resistors; alternatively, use 330 ohm resistors
- 1 1-megaohm ($M\Omega$) resistor
- 1 IRF510 n-channel MOSFET
- 1 12V computer cooling fan
- 1 12V AC adapter, to power fan

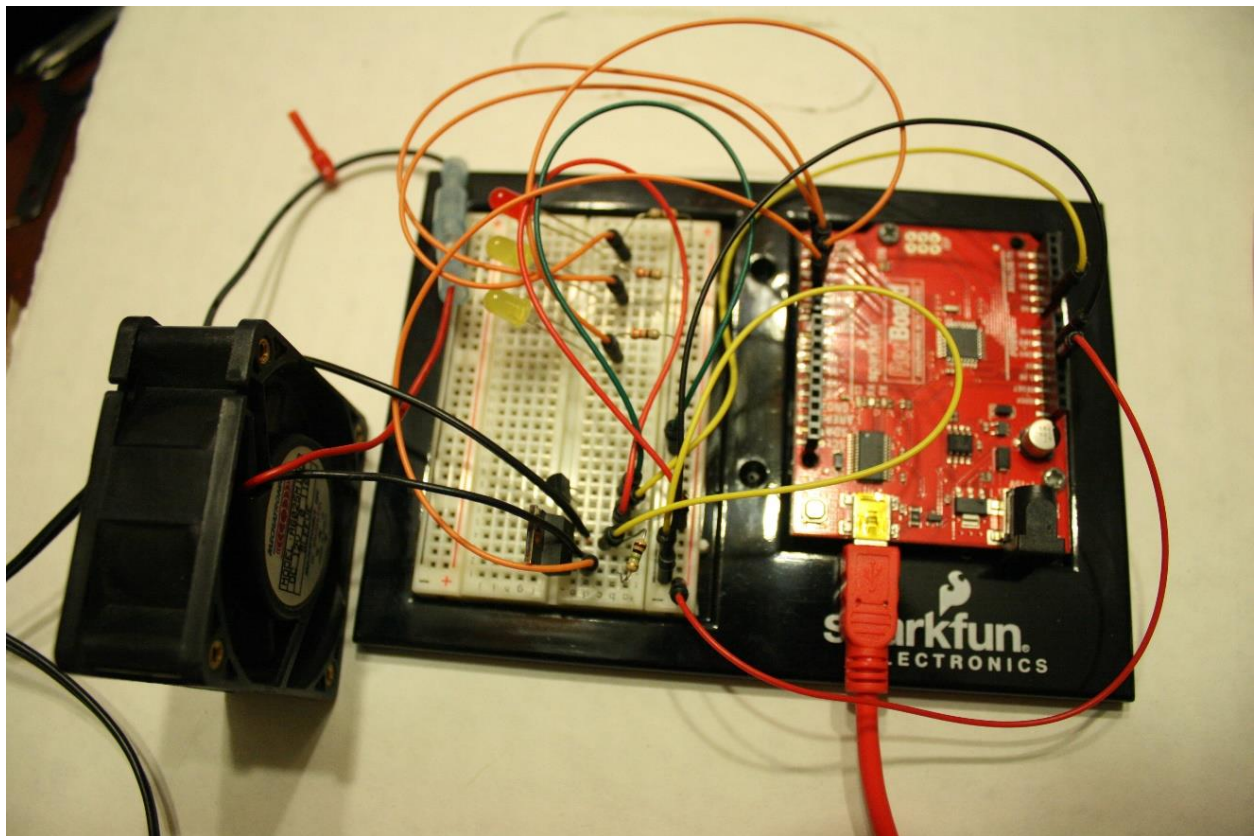

Building the Circuit

To construct the circuit for this activity, please follow the circuit diagram below.

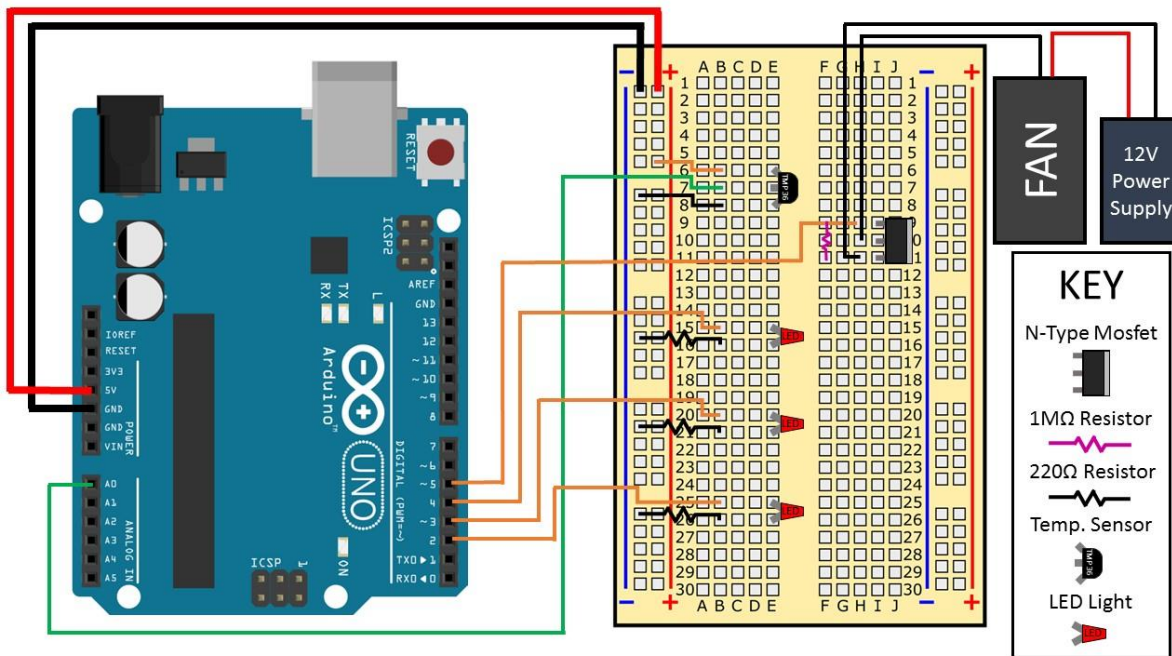

Note that both the TMP36 temperature sensor and the n-channel MOSFET have specific directional orientations. Orient them as shown in the diagram or they may burn out. Also note that the resistors used for the LEDs and the MOSFET are NOT THE SAME RESISTANCE.

Splicing the fan to the 12V power supply can be done via several different methods such as soldering, attaching connector ends to both leads, or simply twisting and taping the wires together.

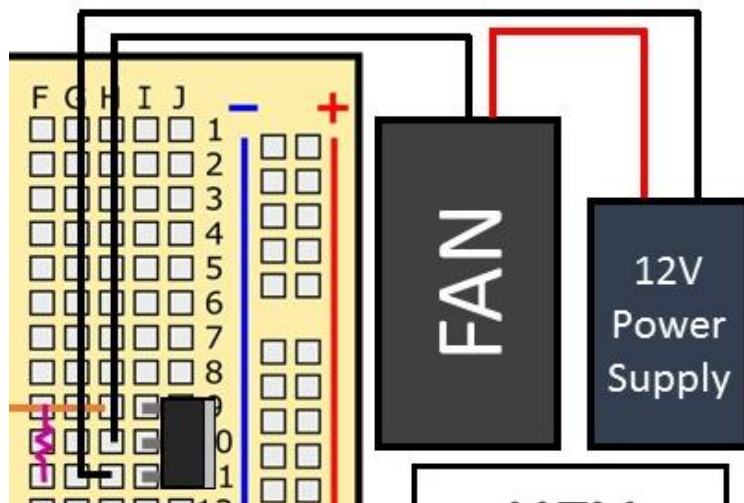

Tip: Pay special attention to the wiring of the n-channel MOSFET to the power adapter and fan since this is the most crucial part of the circuit. Notice that the 1 MΩ resistor attaches to F9 and F11 on the breadboard.